

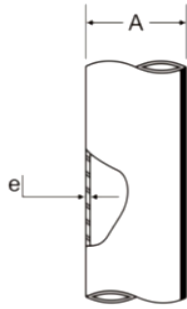

**Conexões Tubulares Solda**

**Tubos**

Ø	A	e	P. máx à 20° C [Kgf/cm²]
1"	25,4	1,2	95,0
1½"	38,1	1,2	50,0
2"	50,8	1,2	30,0
2"	50,8	1,5	50,0
2½"	63,5	1,5	30,0
3"	76,2	1,5	18,0
3"	76,2	2,0	36,0
4"	101,6	2,0	18,0
5"	127,0	2,0	17,0
6"	152,4	2,0	16,0



**Curva 45° solda**

Ø	A	e
1"	14,6	1,5
1½"	21,9	1,5
2"	29,2	1,5
2½"	36,5	1,5
3"	43,7	2,0
4"	58,3	2,0
5"	72,9	2,5
6"	87,5	2,0
8"	116,6	3,0

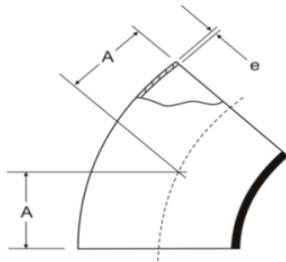

**3 Curva 180° solda**

Ø	A	B	e
1"	76,2	50,8	1,5
1½"	114,4	76,2	1,5
2"	152,4	101,6	1,5
2½"	190,5	127,0	1,5
3"	228,6	152,4	2,0
4"	304,8	203,2	2,0
5"	381,0	254,0	2,5
6"	457,2	304,8	2,5

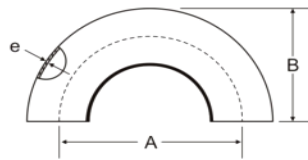

(medidas e mm)

**Tê reto de redução solda**

Ø	A	B	e
1½" x 1"	114,4	57,2	1,5
2" x 1"	152,4	76,2	1,5
2" x 1½"	152,4	76,2	1,5
2½" x 1"	154,0	77,0	1,5
2½" x 1½"	154,0	77,0	1,5
2½" x 2"	154,0	77,0	1,5
3" x 1½"	166,0	83,0	2,0
3" x 2"	166,0	83,0	2,0
3" x 2½"	166,0	83,0	2,0
4" x 2"	197,0	98,5	2,0
4" x 2½"	197,0	98,5	2,0
4" x 3"	197,0	95,5	2,0
6" x 4"	226,0	113,0	2,0

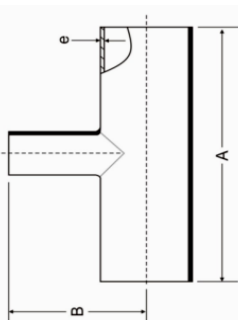

Outras bitolas sob. Consulta.

**Tê reto solda / cruzeta solda**

Ø	A	B	e
1"	96,0	48,0	1,5
1½"	114,4	57,2	1,5
2"	152,4	76,2	1,5
2½"	154,0	77,0	1,5
3"	166,0	83,0	2,0
4"	197,0	98,5	2,0
5"	211,4	105,7	2,5
6"	226,0	113,0	2,0
8"	241,4	120,7	3,0

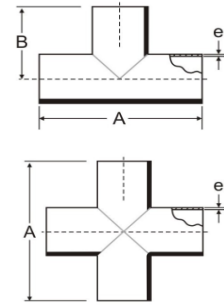

Outras bitolas sob consulta.

**Curva 90° solda**

Ø	A	e
1"	38,1	1,5
1½"	57,2	1,5
2"	76,2	1,5
2½"	95,3	1,5
3"	114,3	2,0
4"	152,4	2,0
5"	190,5	2,5
6"	228,6	2,0
8"	304,8	3,0

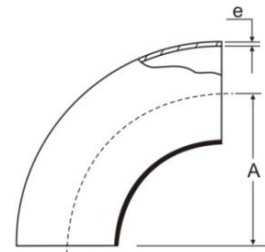

**Tê 45° solda**

Ø	A	B	C	e
1"	152,4	127,0	25,8	2,0
1½"	187,3	157,1	30,4	2,0
2"	222,2	180,9	41,5	2,0
2½"	254,0	215,7	38,2	2,0
3"	273,0	225,2	47,8	2,0
4"	325,4	272,8	52,0	2,0

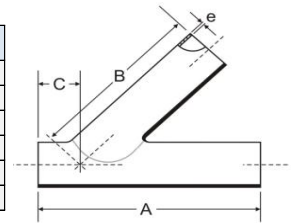

Fornecemos também com outro ângulo e na opção de redução

**Redução cônica solda**

Ø	A conc.	A exc.	e
1½" x 1"	44,0	39,0	2,0
2" x 1"	86,0	78,0	2,0
2" x 1½"	42,0	39,0	2,0
2½" x 1"	128,0	117,0	2,0
2½" x 1½"	84,0	78,0	2,0
2½" x 2"	42,0	39,0	2,0
3" x 1½"	126,0	117,0	2,0
3" x 2"	84,0	78,0	2,0
3" x 2½"	42,0	40,0	2,0
4" x 2"	167,0	157,0	2,0
4" x 2½"	125,0	118,0	2,0
4" x 3"	83,0	78,0	2,0
5" x 4"	83,0	78,0	2,0
6" x 4"	160,0	156,0	2,0
6" x 5"	83,0	78,0	2,0
8" x 6"	160,0	156,0	2,5

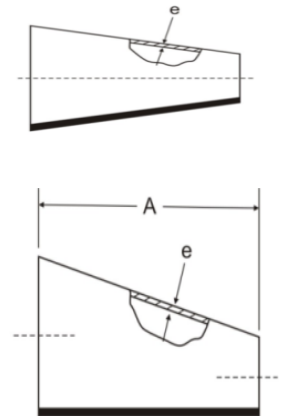

(medidas e mm)

Outras bitolas sob. Consulta.



**União TC**

Ø	A		
	curta	longa	exp
1/2"	27,2	-	-
3/4"	27,2	-	-
1"	27,2	59,0	39,8
1 1/2"	27,2	59,0	45,8
2"	27,2	59,0	52,6
2 1/2"	27,2	59,0	59,0
3"	27,2	59,0	61,8
4"	33,6	59,0	-
5"	40,6	-	-
6"	45,7	59,0	-
8"	33,6	59,0	-

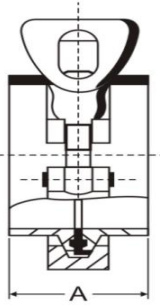

(medidas e mm)

**Niple solda TC / Niple expansão TC**

Ø	A	A	B	exp
	curto	longo		
1/2"	12,7	-	25,4	-
3/4"	12,7	-	25,4	-
1"	12,7	21,5	50,0	-
1 1/2"	12,7	21,5	50,0	19
2"	12,7	21,5	64,0	22
2 1/2"	12,7	21,5	77,0	25,4
3"	12,7	21,5	91,0	28,6
4"	15,9	28,6	119,0	30
5"	19,2	28,6	150,0	-
6"	21,5	28,6	167,0	-
8"	22,1	28,6	220,6	-

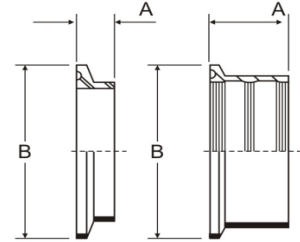

**Abraçadeira TC**

Ø	A		Pressão de serviço[Kfg/cm²]	
	normal	alta	normal	alta pressão
	1/2" e 3/4"	37,0	28,0	40,0
1" e 1 1/2"	54,0	52,0	34,0	70,0
2"	67,0	66,0	28,0	70,0
2 1/2"	81,0	79,0	26,0	70,0
3"	81,0	79,0	22,0	70,0
4"	94,0	92,0	12,0	70,0
6"	122,0	120,0	8,0	20,0
6"	172,0	170,0		

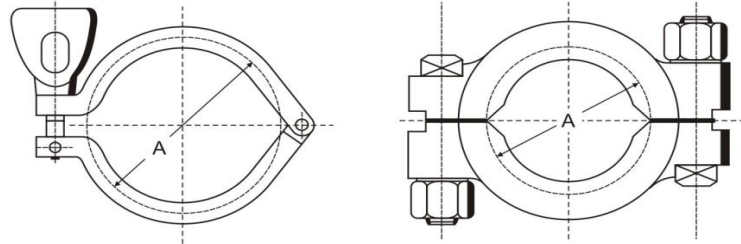

(medidas e mm)

As pressões acima referem-se a t=20°C.

**anel de vedação TC**

Ø	A	e
1/2"	34,0	1,8
3/4"	34,0	1,8
1"	52,0	1,8
1 1/2"	52,0	1,8
2"	66,0	1,8
2 1/2"	79,0	1,8
3"	93,0	1,8
4"	121,0	1,8
6"	169,0	1,8
8"	223,0	1,8

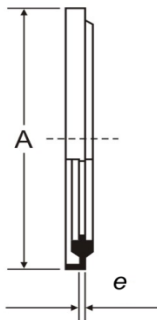

(medidas e mm)

**Tampão TC**

Ø	A	e
1"	50,0	6,3
1 1/2"	50,0	6,3
2"	64,0	6,3
2 1/2"	77,0	6,3
3"	91,0	6,3
4"	119,0	7,9
6"	167,0	7,9

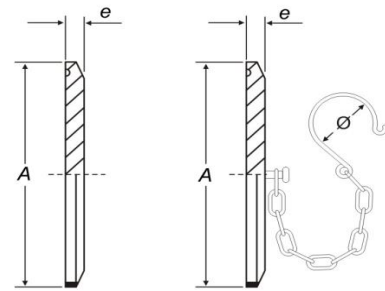

(medidas e mm)

**adaptador TC x mangueira**

Ø	A
1"	72,7
1 1/2"	92,7
2"	92,7
2 1/2"	112,7
3"	112,7
4"	115,9
6"	135,9

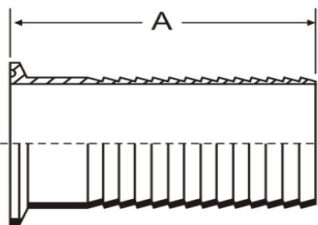

É fornecido também com redução

(medidas e mm)

**Niple adaptador TC tipo L / tipo N**

Ø	A		
	tipo L	tipo N	BSP/NPT
1"	59,7	59,7	47,7
1 1/2"	64,7	61,7	52,7
2"	69,7	63,7	57,7
2 1/2"	74,7	71,7	71,7
3"	79,7	75,7	67,7
4"	90,9	80,9	75,9

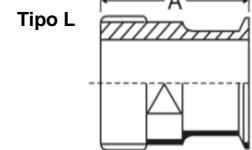
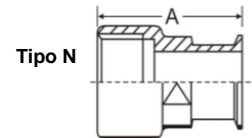

(medidas e mm)



**União RJT**

Ø	A	
	solda	exp.
1"	35,9	41,2
1½"	35,9	49,2
2"	35,9	53,2
2½"	35,9	65,2
3"	35,9	65,2
4"	35,9	-
5"	47,8	-
6"	47,8	-

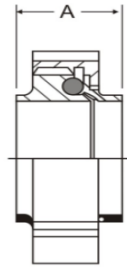

(medidas e mm)

**União DIN**

Ø	A
½"	34,0
¾"	34,0
1"	38,0
1½"	38,0
2"	39,0
2½"	40,0
3"	48,8
4"	49,5
5"	62,0
6"	69,5

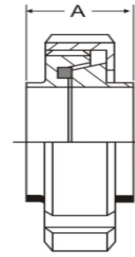

(medidas e mm)

**União SMS**

Ø	A	
	solda	exp
1½"	34,9	38,9
2"	34,9	44,9
2½"	34,9	46,9
1"	38,9	46,9
3"	38,9	66,9
4"	53,9	-

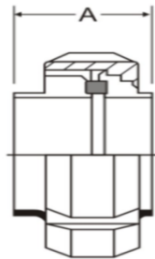

(medidas e mm)

**Porca Circular**

Ø	RJT		SMS		DIN	
	A	B	A	B	A	B
½"	-	-	-	-	18,0	38,0
¾"	-	-	-	-	18,0	44,0
1"	22,0	59,0	20,0	51,0	21,0	63,0
1½"	22,0	72,0	25,0	74,0	21,0	78,0
2"	22,0	86,0	26,0	84,0	22,0	92,0
2½"	22,0	98,0	30,0	100,0	25,0	112,0
3"	22,0	111,0	32,0	114,0	29,0	127,0
4"	22,0	136,0	45,0	154,0	31,0	148,0
5"	26,0	187,0	-	-	35,0	178,0
6"	26,0	225,0	-	-	40,0	210,0

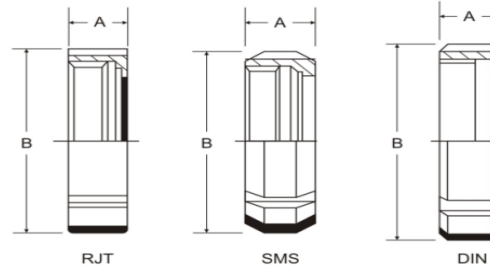

Fornecemos também Porca Tampão e Porca Tampão com corrente

**Tampão**

Ø	RJT		SMS		DIN	
	A	B	A	B	A	B
1"	10,0	42,0	7,5	35,5	10,0	44,0
1½"	10,0	54,0	8,0	55,0	10,0	56,0
2"	10,0	67,0	9,0	65,0	11,0	68,0
2½"	10,0	79,7	9,0	80,0	12,0	86,0
3"	10,0	92,6	11,0	93,0	12,0	100,0
4"	10,0	117,3	13,0	127,0	15,0	121,0
5"	10,0	143,0	-	-	17,0	156,0
6"	10,0	168,0	-	-	19,0	176,0

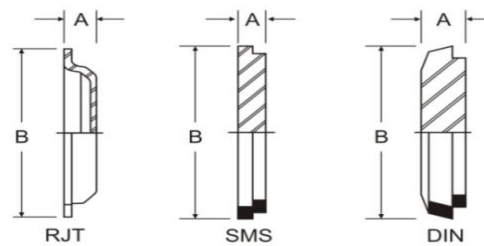

Fornecemos também tampão com corrente

**Anéis de Vedação**

Ø	RJT		SMS		DIN	
	A	B	A	B	A	B
1"	6,6	33,2	5,5	32,0	5,0	40,0
1½"	6,6	45,9	5,5	48,0	5,0	52,0
2"	6,6	58,6	5,5	61,0	5,0	64,0
2½"	6,6	71,3	5,5	73,5	5,0	81,0
3"	6,6	84,0	5,5	86,0	5,0	95,0
4"	6,6	109,7	5,5	103,5	6,0	114,0
5"	6,6	142,0	-	-	7,0	142,0
6"	6,6	158,0	-	-	7,0	167,0

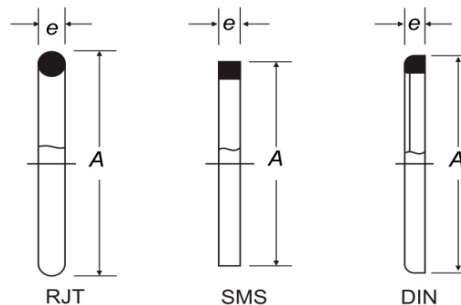



**Macho Solda**

Ø	RJT		SMS		DIN	
	A	B	A	B	A	B
1/2"	-	-	-	-	21	28
3/4"	-	-	-	-	21	34
1"	26,5	49,4	16	39,8	24	52
1 1/2"	26,5	58,1	20	59,8	24	65
2"	26,5	72,4	20	69,8	24	78
2 1/2"	26,5	85,1	24	84,8	27	95
3"	26,5	97,8	24	97,8	31	110
4"	26,5	123,2	35	131,2	31	130
5"	26,5	150	-	-	46	170
6"	26,5	175	-	-	50	190

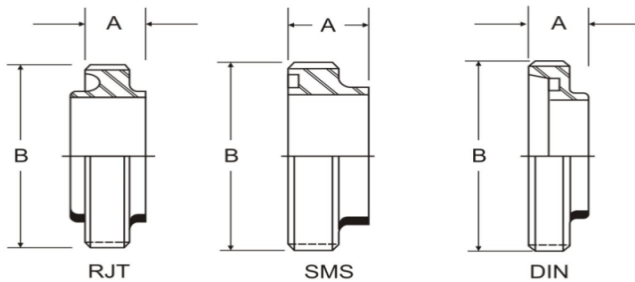

Sob consulta

**Macho Expansão**

Ø	RJT		SMS	
	A	B	A	B
1"	20	45,4	20	39,8
1 1/2"	24	58,1	23	59,8
2"	28	72,4	25	69,8
2 1/2"	32	85,1	30	84,8
3"	32	97,8	35	97,8

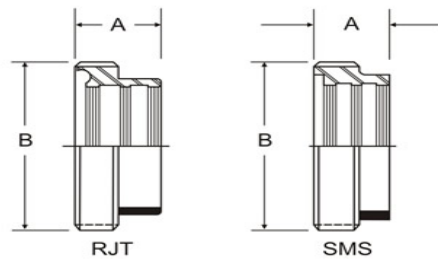

**Macho de Redução Solda**

Ø	RJT		SMS		DIN	
	A	B	A	B	A	B
1 1/2" x 1"	26,5	58,1	20,0	60,1	24,0	65,0
2" x 1"	26,5	72,4	20,0	70,1	24,0	78,0
2" x 1 1/2"	26,5	72,4	20,0	70,1	24,0	78,0
2 1/2" x 1"	26,5	85,1	24,0	85,1	27,0	95,0
2 1/2" x 1 1/2"	26,5	85,1	24,0	85,1	27,0	95,0
2 1/2" x 2"	26,5	85,1	24,0	85,1	27,0	95,0
3" x 1 1/2"	26,5	97,8	24,0	98,1	31,0	110,0
3" x 2"	26,5	97,8	24,0	98,1	31,0	110,0
3" x 2 1/2"	26,5	97,8	24,0	98,1	31,0	110,0
4" x 2"	26,5	123,2	24,0	131,3	31,0	130,0
4" x 2 1/2"	26,5	123,2	24,0	131,3	31,0	130,0
4" x 3"	26,5	123,2	24,0	131,3	31,0	130,0
6" x 4"	26,5	175,0	-	-	45,0	190,0

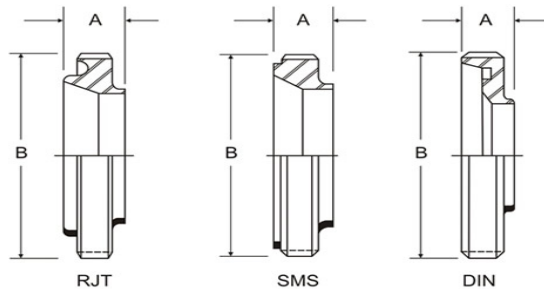

**Macho de Redução Expansão**

Ø	RJT		SMS		DIN	
	A	B	A	B	A	B
1 1/2" x 1"	25,0	58,1	25,0	59,8	22,5	50,6
2" x 1"	26,0	72,4	26,5	69,8	26,0	64,1
2" x 1 1/2"	28,5	72,4	28,0	69,8	22,5	64,1
2 1/2" x 1"	25,5	85,1	30,0	84,8	23,5	77,6
2 1/2" x 1 1/2"	30,0	85,1	28,0	84,8	26,0	77,6
2 1/2" x 2"	33,0	85,1	30,0	84,8	22,5	77,6
3" x 1 1/2"	30,0	97,8	29,0	97,8	23,5	91,1
3" x 2"	34,0	97,8	31,0	97,8	26,0	91,1
3" x 2 1/2"	36,0	97,8	35,0	97,8	22,5	91,1

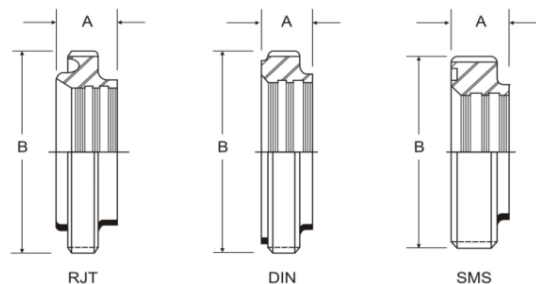



**Curva 90° 2TC**

Ø	A
1"	50,8
1½"	69,9
2"	88,9
2½"	108,0
3"	127,0
4"	168,3
6"	244,5

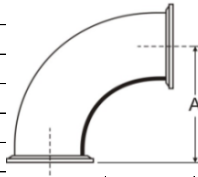

(medidas e mm)

**Tê reto 3TC**

Ø	A	B
1"	121,4	60,7
1½"	139,8	69,9
2"	177,8	88,9
2½"	179,4	89,7
3"	191,4	95,7
4"	228,8	114,4
6"	257,8	128,9

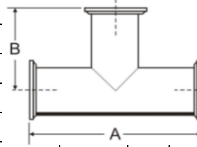

**Curva 180° 2TC**

Ø	A	B
1"	76,2	63,5
1½"	114,4	88,9
2"	152,4	114,3
2½"	190,5	139,7
3"	228,6	165,1
4"	304,8	219,1
6"	457,2	320,7

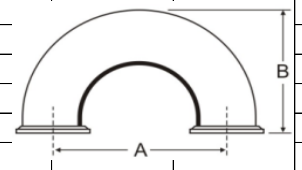

(medida e mm)

**Curva 45° 2TC**

Ø	A
1"	27,3
1½"	34,6
2"	41,9
2½"	49,2
3"	56,4
4"	74,2
6"	103,4

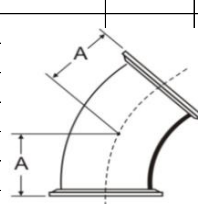

(medidas e mm)

**Cruzeta 4TC**

Ø	A
1"	121,4
1½"	139,8
2"	177,8
2½"	179,4
3"	191,4
4"	228,8

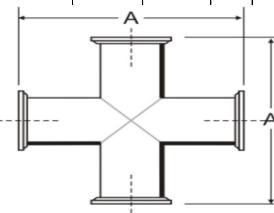

**Tê 45° 3TC**

Ø	A	B	C
1"	177,8	139,7	38,5
1½"	212,7	169,8	43,1
2"	247,6	193,6	54,2
2½"	279,4	228,4	50,9
3"	298,4	237,9	60,5
4"	357,2	288,7	67,9

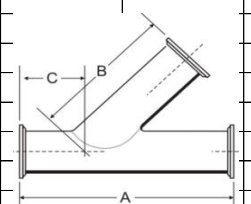

(medidas e mm)

**Curva de redução 90° 2TC**

Ø	A	B
1½" x 1"	50,8	50,8
2" x 1"	50,8	50,8
2" x 1½"	69,9	69,9
2½" x 1"	50,8	50,8
2½" x 1½"	69,9	69,9
2½" x 2"	88,9	88,9
3" x 1½"	69,9	69,9
3" x 2"	88,9	88,9
3" x 2½"	108,0	108,0
4" x 2"	88,9	92,1
4" x 2½"	108,0	111,2
4" x 3"	127,0	130,2
6" x 4"	168,3	168,3

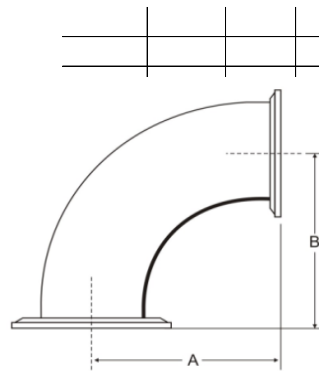

**Tê redução 3TC**

Ø	A	B
1½" x 1"	139,8	69,9
2" x 1"	177,8	88,9
2" x 1½"	177,8	88,9
2½" x 1"	179,4	89,7
2½" x 1½"	179,4	89,7
2½" x 2"	179,4	89,7
3" x 1½"	191,4	95,7
3" x 2"	191,4	95,7
3" x 1½"	191,4	95,7
4" x 2"	228,8	111,2
4" x 2½"	228,8	111,2
4" x 3"	228,8	112,2
6" x 4"	257,8	128,9

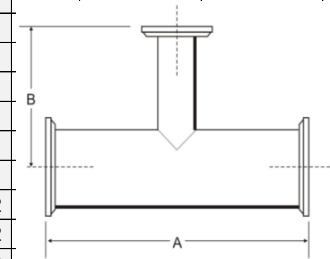

**Niple de redução solda/expansão TC**

Ø	A		B
	Solda	exp.	
1½" x 1"	12,7	19,0	50,0
2" x 1"	12,7	19,0	64,0
2" x 1½"	12,7	22,0	64,0
2½" x 1"	12,7	19,0	77,0
2½" x 1½"	12,7	22,0	77,0
2½" x 2"	12,7	25,4	77,0
3" x 1½"	12,7	22,0	91,0
3" x 2"	12,7	25,4	91,0
3" x 2½"	12,7	28,6	91,0
4" x 2"	12,7	25,4	119,0
4" x 2½"	12,7	28,6	119,0
4" x 3"	12,7	30,0	119,0
6" x 4"	15,9		167,0

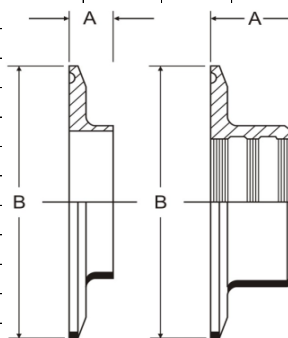

**Redução Cônica 2TC**

Ø	A
1½" x 1"	64,4
2" x 1"	103,4
2" x 1½"	64,4
2½" x 1"	142,4
2½" x 1½"	103,4
2½" x 2"	64,4
3" x 1½"	142,4
3" x 2"	103,4
3" x 1½"	64,4
4" x 2"	184,6
4" x 2½"	145,6
4" x 3"	106,6
6" x 4"	187,8

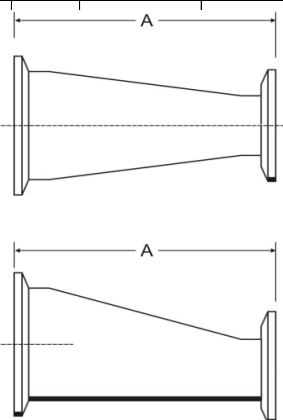

(medidas e mm)

Outras bitolas sob consulta.



**Niple Solda**

(medidas e mm)

Ø	RJT		SMS		DIN	
	A	B	A	B	A	B
1/2"	-	-	-	-	17,0	22,5
3/4"	-	-	-	-	17,0	28,5
1"	13,0	42,0	13,0	35,3	20,0	44,0
1 1/2"	13,0	53,9	13,0	55,0	20,0	56,0
2"	13,0	67,6	13,0	65,0	21,0	68,5
2 1/2"	13,0	80,3	13,0	80,0	24,0	86,0
3"	13,0	93,0	13,0	93,0	24,0	121,0
4"	15,0	117,7	17,0	127,0	28,0	121,0
5"	20,0	145,0	-	-	28,0	150,0
6"	20,0	168,0	-	-	37,0	176,0

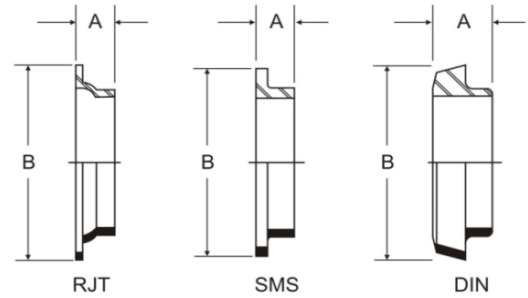

Sob consulta

**Niple Expansão**

Ø	RJT		SMS	
	A	B	A	B
1"	20,0	41,3	17,0	35,5
1 1/2"	24,0	54,0	20,0	55,0
2"	28,0	66,7	20,0	65,0
2 1/2"	32,0	79,3	25,0	80,0
3"	32,0	92,0	30,0	93,0

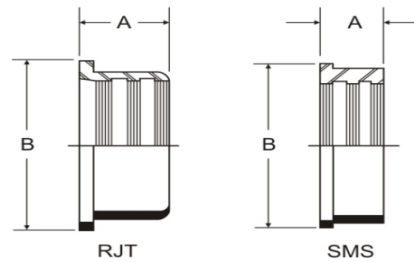

**Niples Redução Solda**

Ø	RJT		SMS		DIN	
	A	B	A	B	A	B
1 1/2" x 1"	13,0	53,9	13,0	55,0	20,0	56,0
2" x 1"	13,0	67,5	13,0	65,0	21,0	68,5
2" x 1 1/2"	13,0	67,5	13,0	65,0	21,0	68,5
2 1/2" x 1"	13,0	80,3	13,0	80,0	24,0	86,0
2 1/2" x 1 1/2"	13,0	80,3	13,0	80,0	24,0	86,0
2 1/2" x 2"	13,0	80,3	13,0	80,0	24,0	86,0
3" x 1 1/2"	13,0	93,0	13,0	93,0	24,0	100,0
3" x 2"	13,0	93,0	13,0	93,0	24,0	100,0
3" x 2 1/2"	13,0	93,0	13,0	93,0	24,0	100,0
4" x 2"	15,0	117,7	17,0	127,0	28,0	121,0
4" x 2 1/2"	15,0	117,7	17,0	127,0	28,0	121,0
4" x 3"	15,0	117,7	17,0	127,0	28,0	121,0
6" x 4"	20,0	168,0	-	-	-	-

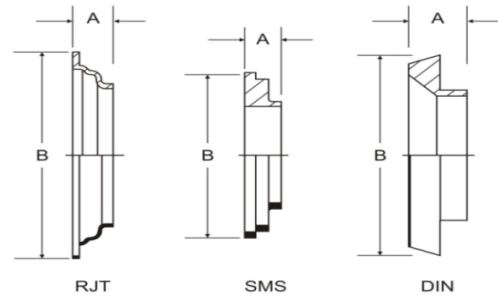

**Niples de Redução Expansão**

Ø	RJT		SMS	
	A	B	A	B
1 1/2" x 1"	24,0	54,0	17,0	55,0
2" x 1"	30,0	66,7	17,0	65,0
2" x 1 1/2"	30,0	66,7	20,0	65,0
2 1/2" x 1"	32,0	79,3	17,0	80,0
2 1/2" x 1 1/2"	32,0	79,3	20,0	80,0
2 1/2" x 2"	32,0	79,3	20,0	80,0
3" x 1 1/2"	35,0	92,0	20,0	93,0
3" x 2"	32,0	92,0	20,0	93,0
3" x 2 1/2"	32,0	92,0	15,0	93,0

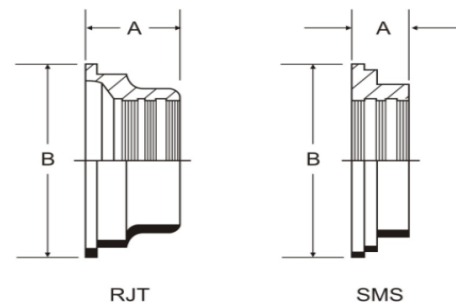



Conexões Roscadas

**Curva 90° 2M**

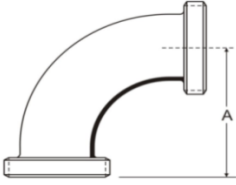

Ø	RJT			SMS			DIN		
	A	B	C	A	B	C	A	B	C
1"	64,6	54,1	62,1	64,6	54,1	62,1	64,6	54,1	62,1
1½"	83,6	77,2	81,2	83,6	77,2	81,2	83,6	77,2	81,2
2"	103,0	96,2	100,2	103,0	96,2	100,2	103,0	96,2	100,2
2½"	122,3	119,2	122,3	122,3	119,2	122,3	122,3	119,2	122,3
3"	141,0	138,3	145,3	141,0	138,3	145,3	141,0	138,3	145,3
4"	179,0	187,4	183,4	179,0	187,4	183,4	179,0	187,4	183,4
6"	255,0	-	278,6	255,0	-	278,6	255,0	-	278,6

(medidas e mm)

**Curva 90° M-NP**

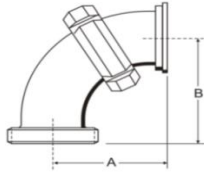

Ø	RJT		SMS		DIN	
	A	B	A	B	A	B
1"	51,1	64,6	51,1	54,1	58,1	62,1
1½"	70,2	83,7	70,2	77,1	77,2	81,2
2"	89,2	102,7	89,2	96,2	97,2	100,2
2½"	108,3	122,0	108,3	119,3	119,3	122,3
3"	127,3	140,8	127,3	138,3	138,3	145,3
4"	167,4	178,9	169,4	187,4	180,4	183,4
6"	248,6	255,1	-	-	265,6	278,6

(medidas e mm)

**Curva 90° 2NP**

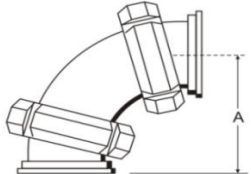

Ø	RJT			SMS			DIN		
	A	B	C	A	B	C	A	B	C
1"	51,1	51,1	58,1	51,1	51,1	58,1	51,1	51,1	58,1
1½"	70,2	70,2	77,2	70,2	70,2	77,2	70,2	70,2	77,2
2"	89,2	89,2	97,2	89,2	89,2	97,2	89,2	89,2	97,2
2½"	108,2	108,2	119,3	108,2	108,2	119,3	108,2	108,2	119,3
3"	127,3	127,3	138,3	127,3	127,3	138,3	127,3	127,3	138,3
4"	167,4	167,4	180,4	167,4	167,4	180,4	167,4	167,4	180,4
6"	248,6	-	265,6	248,6	-	265,6	248,6	-	265,6

(medidas e mm)

**Curva 45° M-NP**

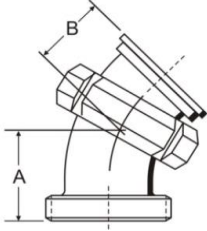

Ø	RJT		SMS		DIN	
	A	B	A	B	A	B
1"	41,1	27,6	30,6	27,6	38,6	34,6
1½"	48,4	34,9	41,9	34,9	45,9	41,9
2"	55,7	42,2	49,2	42,2	53,2	50,2
2½"	63	49,5	60,5	49,5	63,5	60,5
3"	70,2	56,7	67,7	56,7	74,7	67,7
4"	84,8	73,3	93,3	75,3	89,3	86,3
6"	114	107,5	-	-	137	124,5

(medidas e mm)

**Curva 180° 2NP**

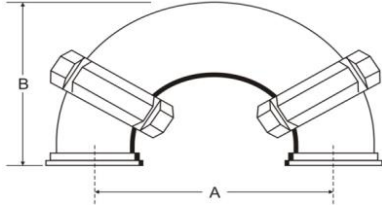

Ø	A	RJT		SMS		DIN	
		B	C	B	C	B	C
1"	76,2	63,8	63,8	63,8	63,8	70,8	
1½"	114,3	89,2	89,2	89,2	89,2	96,2	
2"	152,4	114,6	114,6	114,6	114,6	122,6	
2½"	190,5	140,0	140,0	140,0	140,0	151,0	
3"	228,6	165,4	165,4	165,4	165,4	176,4	
4"	304,8	218,2	218,2	220,2	220,2	231,2	
6"	457,2	324,8	-	-	-	341,8	

(medidas e mm)

**Curva de Redução 90° M-NP**

Ø	RJT		SMS		DIN	
	A	B	A	B	B	
1½" x 1"	51,1	64,6	51,1	54,1	58,1	62,1
2" x 1"	51,1	64,6	51,1	54,1	59,1	62,1
2" x 1½"	70,2	83,6	70,2	77,2	78,2	81,2
2½" x 1"	51,1	64,6	51,1	54,1	62,1	62,1
2½" x 1½"	70,2	83,6	70,2	77,2	82,2	81,2
2½" x 2"	89,2	103	89,2	96,2	100,2	100,2
3" x 1½"	70,2	83,6	70,2	77,2	81,2	81,2
3" x 2"	89,2	103	89,2	96,2	100,2	100,2
3" x 2½"	108,3	122,3	108	119	119,3	122,3
4" x 2"	91,2	103	93,2	96,2	104,2	100,2
4" x 2½"	110,3	122,3	112	119	123,3	122,3
4" x 3"	129,3	141	131	138	142,3	145,3

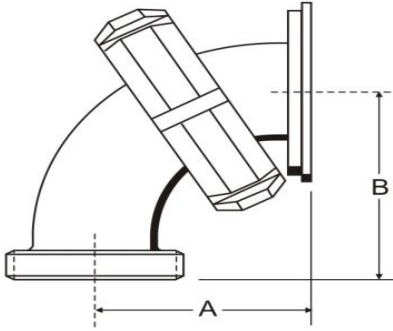



**Tê Reto 3M**

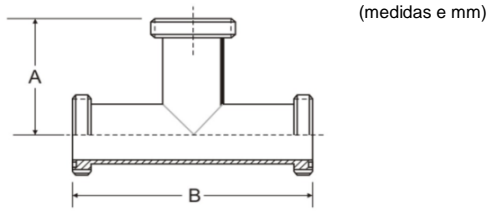

Ø	RJT		SMS		DIN	
	A	B	A	B	A	B
1"	149,0	74,5	128,0	64,0	144,0	72,0
1½"	167,4	83,7	154,4	77,2	162,4	81,2
2"	205,4	102,7	192,4	96,2	200,4	100,2
2½"	207,0	103,5	202,0	101,0	208,0	104,0
3"	219,0	109,5	214,0	107,0	228,0	114,0
4"	250,0	125,0	267,0	133,5	259,0	129,5
6"	279,0	139,5	-	-	326,0	163,0

**Tê Reto 3 NP**

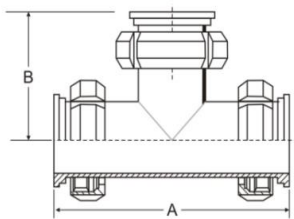

Ø	RJT		SMS		DIN	
	A	B	A	B	A	B
1"	122,0	61,0	122,0	61,0	136,0	68,0
1½"	140,4	70,2	140,4	70,2	154,4	77,2
2"	178,4	89,2	178,4	89,2	194,4	97,2
2½"	180,0	90,0	180,0	90,0	202,0	101,0
3"	192,0	96,0	192,0	96,0	214,0	107,0
4"	227,0	113,5	231,0	115,5	253,0	126,5
6"	266,0	133,0	-	-	300,0	150,0

**Tê Reto de Redução 3M**

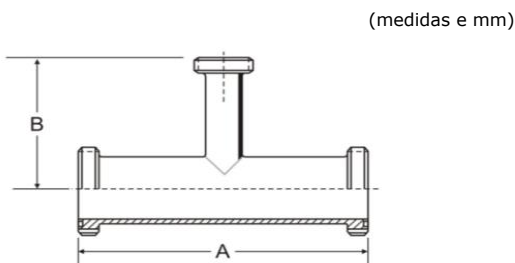

Ø	Ø	RJT		SMS		DIN	
		A	B	A	B	A	B
1½"	1"	167,4	83,7	154,4	77,2	162,4	81,2
2"	1"	205,4	102,7	192,4	96,2	200,4	100,2
2"	1½"	205,4	102,7	192,4	96,2	200,4	100,2
2½"	1"	205,4	102,7	202,0	101,0	208,0	104,0
2½"	1½"	207,0	103,5	202,0	101,0	208,0	104,0
2½"	2"	207,0	103,5	202,0	101,0	208,0	104,0
3"	1½"	219,0	109,5	214,0	107,0	228,0	114,0
3"	2"	219,0	109,5	214,0	107,0	228,0	114,0
3"	2½"	210,0	109,5	214,0	107,0	228,0	114,0
4"	2"	250,0	125,0	267,0	133,5	259,0	129,5
4"	2½"	250,0	125,0	267,0	133,5	259,0	129,5
4"	3"	250,0	125,0	267,0	133,5	259,0	129,5
6"	4"	279,0	139,5	-	-	-	-

**Tê Reto M-NP-NP**

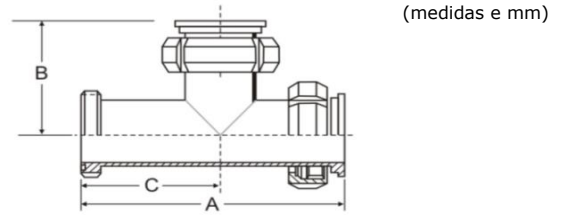

Ø	RJT			SMS			DIN		
	A	B	C	A	B	C	A	B	C
1"	135,5	61,0	74,5	125,0	61,0	64,0	140,0	68,0	72,0
1½"	153,9	70,2	83,7	147,4	70,2	77,2	158,4	77,2	81,2
2"	191,9	89,2	102,7	185,4	89,2	96,2	197,4	97,2	100,2
2½"	193,5	90,0	103,5	191,0	90,0	101,0	205,0	101,0	104,0
3"	205,5	96,0	109,5	203,0	96,0	107,0	221,0	107,0	114,0
4"	238,5	113,5	125,0	249,0	115,0	133,5	256,0	126,5	129,5
6"	272,5	133,0	139,5	-	-	-	313,0	150,0	163,0

**Tê 45° 3M**

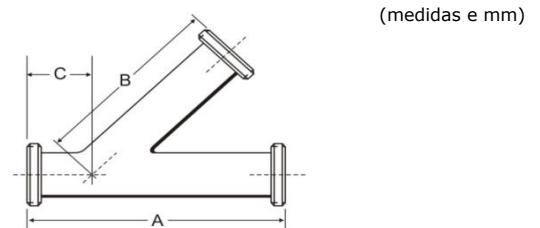

Ø	RJT			SMS			DIN		
	A	B	C	A	B	C	A	B	C
1"	205,5	153,5	52,3	184,4	143,0	41,8	200,4	151,0	49,8
1½"	240,3	183,6	56,9	227,3	177,1	50,4	235,3	181,1	54,4
2"	275,2	207,4	68,0	262,2	200,9	61,5	270,2	204,9	65,5
2½"	307,0	242,2	64,7	302,0	239,7	62,2	308,0	242,7	65,2
3"	326,0	251,7	74,3	321,0	249,2	71,8	335,0	256,2	78,8
4"	378,4	299,3	78,5	395,4	307,8	87,0	387,4	303,8	83,0

**Cruzeta 4M**

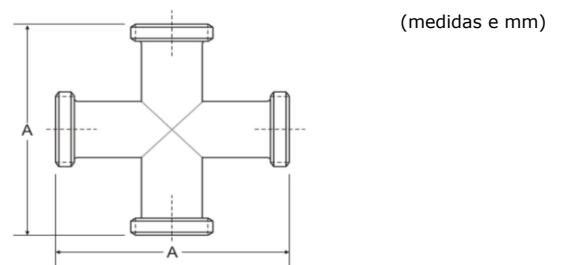

Ø	RJT	SMS	DIN
	A	A	A
1"	149,0	128,0	144,0
1½"	167,4	154,4	162,4
2"	205,4	192,4	200,4
2½"	207,0	202,0	208,0
3"	219,0	214,0	208,0
4"	250,0	267,0	259,0
6"	279,0	-	326,0





**Redução Cônica 2M**

(medidas e mm)

Ø	RJT		SMS		DIN	
	conc.	exc.	conc.	exc.	conc.	exc.
1½" x 1"	97,0	92,0	80,0	75,0	92,0	87,0
2"x1" x 1"	139,0	131,0	122,0	114,0	134,0	126,0
2" x 1½"	95,0	92,0	82,0	79,0	90,0	87,0
2½" x 1"	181,0	170,0	168,0	157,0	182,0	171,0
2½" x 1½"	137,0	131,0	128,0	122,0	135,0	129,0
2½" x 2"	95,0	92,0	86,0	83,0	93,0	90,0
3" x 1½"	179,0	170,0	170,0	161,0	181,0	172,0
3" x 2"	137,0	131,0	128,0	122,0	139,0	133,0
3" x 2½"	95,0	93,0	90,0	88,0	100,0	98,0
4" x 2"	220,0	210,0	222,0	212,0	222,0	212,0
4" x 2½"	178,0	171,0	184,0	177,0	183,0	176,0
4" x 3"	136,0	131,0	142,0	137,0	145,0	140,0

Concêntrica

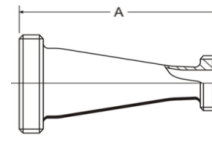

Excêntrica

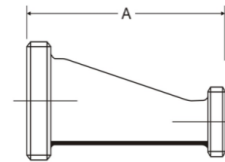

Outras bitolas sob consulta.

**Redução Cônica M NP**

(medidas e mm)

Ø	RJT		SMS		DIN	
	conc.	exc.	conc.	exc.	conc.	exc.
1½" x 1"	83,5	78,5	77,0	72,0	88,0	83,0
2" x 1"	125,5	117,5	115,0	107,0	130,0	122,0
2" x 1½"	81,5	78,5	75,0	72,0	87,0	84,0
2½" x 1"	167,5	156,5	157,0	146,0	179,0	168,0
2½" x 1½"	123,5	117,5	117,0	111,0	132,0	126,0
2½" x 2"	81,5	78,5	75,0	72,0	90,0	87,0
3" x 1½"	165,5	156,5	159,0	150,0	177,0	168,0
3" x 2"	123,5	117,5	121,0	115,0	136,0	130,0
3" x 2½"	81,5	79,5	79,0	77,0	97,0	95,0
4" x 2"	208,5	198,5	215,0	205,0	219,0	209,0
4" x 2½"	166,5	159,5	173,0	166,0	180,0	173,0
4" x 3"	124,5	119,5	131,0	126,0	138,0	133,0

Concêntrica

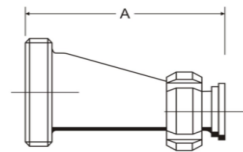

Excêntrica

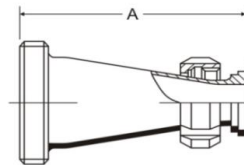

**Redução Cônica 2 NP**

(medidas e mm)

Ø	RJT		SMS		DIN	
	conc.	exc.	conc.	exc.	conc.	exc.
1½" x 1"	70,0	65,0	70,0	65,0	84,0	79,0
2" x 1"	112,0	104,0	112,0	104,0	126,0	118,0
2" x 1½"	68,0	65,0	68,0	65,0	83,0	80,0
2½" x 1"	154,0	143,0	154,0	143,0	172,0	161,0
2½" x 1½"	110,0	104,0	110,0	104,0	128,0	122,0
2½" x 2"	68,0	63,0	68,0	63,0	87,0	84,0
3" x 1½"	152,0	143,0	152,0	143,0	170,0	161,0
3" x 2"	110,0	104,0	110,0	104,0	129,0	123,0
3" x 2½"	68,0	66,0	68,0	66,0	90,0	88,0
4" x 2"	195,0	185,0	197,0	187,0	216,0	206,0
4" x 2½"	153,0	146,0	155,0	148,0	177,0	170,0
4" x 3"	111,0	106,0	113,0	108,0	135,0	130,0

Concêntrica

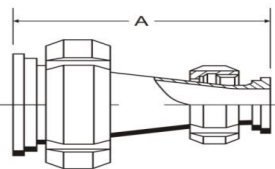

Excêntrica

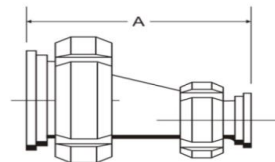



**Macho adaptador p/ mangueira**

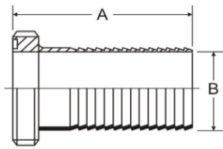

(medidas e mm)

Ø	A			B
	RJT	SMS	DIN	
1"	86,5	76,0	84,0	25,5
1½"	106,5	100,0	104,0	38,1
2"	106,5	100,0	104,0	50,8
2½"	126,5	124,0	127,0	63,5
3"	126,5	124,0	131,0	76,2
4"	126,5	135,0	131,0	101,6
6"	126,5	-	170,0	152,4

**Niple Adaptador p/ mangueira**

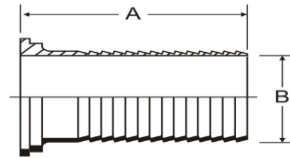

(medidas e mm)

Ø	A			B
	RJT	SMS	DIN	
1"	73,0	73,0	80,0	25,4
1½"	93,0	93,0	100,0	38,1
2"	93,0	93,0	101,0	50,8
2½"	113,0	113,0	124,0	63,5
3"	113,0	113,0	124,0	76,2
4"	115,0	117,0	128,0	101,6
6"	140,0	-	152,0	125,4

**Macho Adaptador Tipo N**

Ø	RJT		SMS		DIN	
	BSP	NPT	BSP	NPT	BST	NPT
1"	73,5	73,5	63,0	63,0	71,0	71,0
1½"	78,5	75,5	72,0	69,0	76,0	73,0
2"	83,5	77,5	77,0	71,0	81,0	75,0
2½"	88,5	85,5	86,0	83,0	89,0	86,0
3"	93,5	89,5	91,0	87,0	98,0	94,0
4"	101,5	91,5	110,0	100,0	106,0	96,0

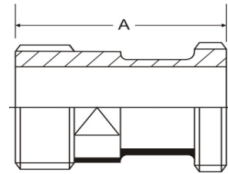

(medidas e mm)

**Niple Porca Adaptador Tipo N**

Ø	RJT		SMS		DIN	
	BSP	NPT	BSP	NPT	BST	NPT
1"	60,0	60,0	60,0	60,0	67,0	67,0
1½"	65,0	62,0	65,0	62,0	72,0	69,0
2"	70,0	64,0	70,0	64,0	78,0	72,0
2½"	75,0	72,0	75,0	72,0	86,0	83,0
3"	80,0	76,0	80,0	76,0	95,0	91,0
4"	90,0	80,0	92,0	82,0	107,0	97,0

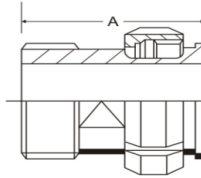

(medidas e mm)

**Macho Adaptador Tipo L**

Ø	RJT		SMS		DIN	
	BSP	NPT	BSP	NPT	BST	NPT
1"	61,5	61,5	51,0	51,0	59,0	59,0
1½"	66,5	66,5	60,0	60,0	64,0	64,0
2"	71,5	71,5	65,0	65,0	69,0	69,0
2½"	76,5	76,5	74,0	74,0	77,0	77,0
3"	81,5	81,5	79,0	79,0	86,0	86,0
4"	86,5	86,5	95,0	95,0	91,0	91,0

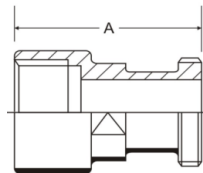

(medidas e mm)

**Niple Porca Adaptador Tipo L**

Ø	RJT		SMS		DIN	
	BSP	NPT	BSP	NPT	BST	NPT
1"	48,0	48,0	48,0	48,0	55,0	55,0
1½"	53,0	53,0	53,0	53,0	60,0	60,0
2"	58,0	58,0	58,0	58,0	66,0	66,0
2½"	63,0	63,0	63,0	63,0	74,0	74,0
3"	68,0	68,0	68,0	68,0	79,0	79,0
4"	75,0	75,0	77,0	77,0	88,0	88,0

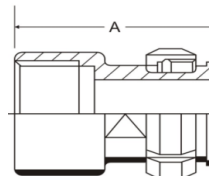



**Aspersores "Spray-ball"**

(medidas e mm)

	Ø	vazão à 2 Kgf/cm <sup>2</sup>	Ø do leque
Padrão	furo	m <sup>3</sup> /h	m
360°	3/32"	16,0	4,0
	1/16"	10,0	3,8
270° superior	3/32"	15,0	40,0
	1/16"	9,0	3,8
270° inferior	3/32"	15,0	4,0
	1/16"	9,0	3,8
180° superior	3/32"	10,0	3,9
	1/16"	6,0	3,7
180° inferior	3/32"	8,0	4,1
	1/16"	5,0	3,9
150° lateral	3/32"	9,0	2,0
150° superior	3/32"	9,0	4,2
150° inferior	3/32"	12,0	3,8

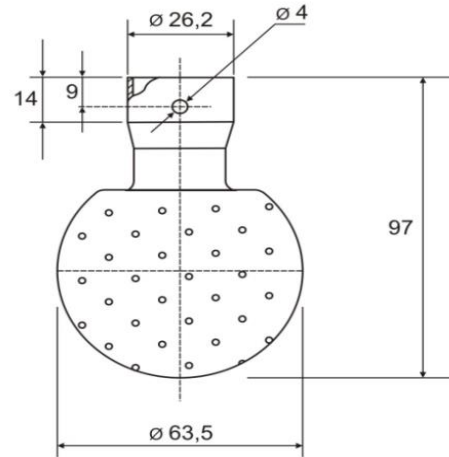

Todos os adaptadores podem ser fornecidos com redução

**Adaptador para Aspersor**

(medidas em mm)

Ø	A				B
	TC	M RJT	M SMS	M DIN	
1"	92,2	106,0	95,5	103,5	800,0
1½"	92,2	106,0	99,5	103,5	800,0
2"	128,2	142,0	135,3	139,3	800,0
2½"	164,7	178,5	176,0	179,0	800,0

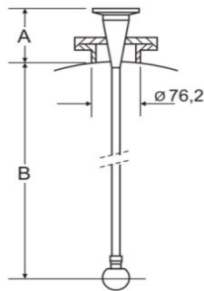

Todos os adaptadores podem ser fornecidos com redução

**Painel de Distribuição de Fluxo**

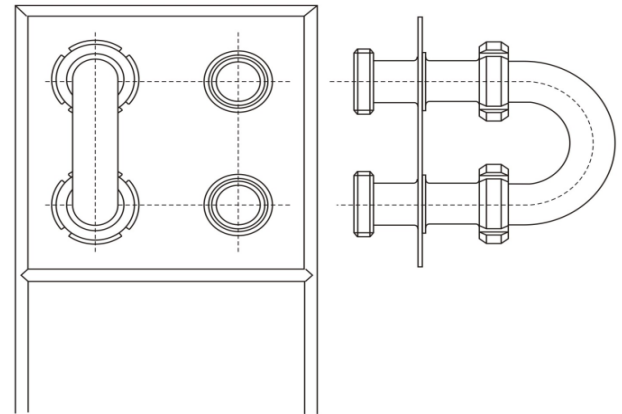

São fabricados sob encomendas com bocas fixa ou removível

**Manômetro**

(medidas e mm)

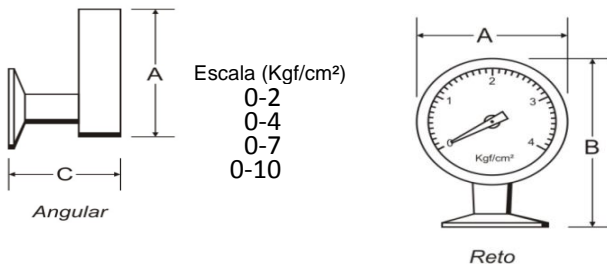

Escala (Kgf/cm<sup>2</sup>)  
0-2  
0-4  
0-7  
0-10

Dimensões			
Ø	A	B	C
2"	100,0	145,0	86,0

Diafragma Sanitário  
Enchimento em glicerina para trabalho em tubulação sob efeito de vibrações

**Termômetro**

(medidas e mm)

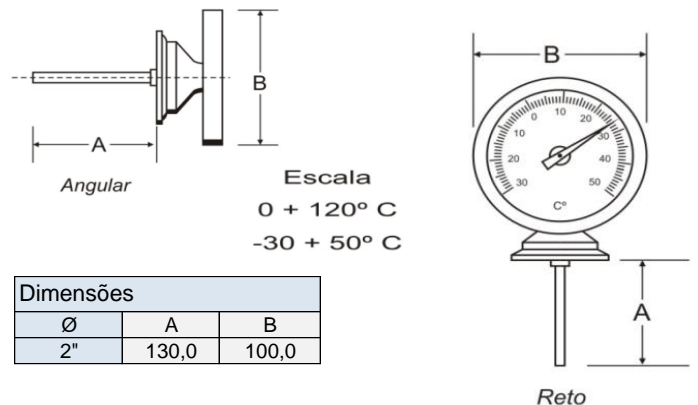

Escala  
0 + 120° C  
-30 + 50° C

Dimensões		
Ø	A	B
2"	130,0	100,0

Com selo bimetálico sanitário



**Abraçadeira Suporte para Tubo**

(medidas e mm)

Ø A	B	C
1"	58,7	43,7
1½"	65,0	50,0
2"	71,4	62,7
2½"	84,1	56,4
3"	77,7	69,1
4"	96,8	81,8
5"	109,5	94,5
6"	122,2	107,2

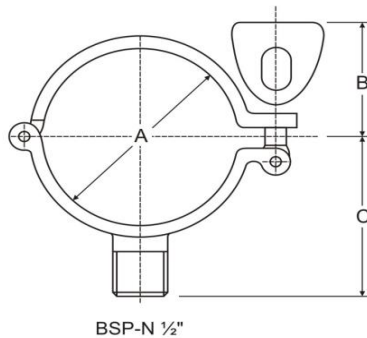

**Luva para Abraçadeira**

(medida e mm)

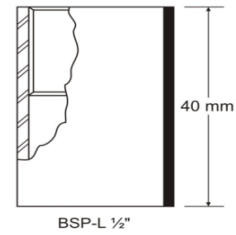

Esta luva geralmente acompanha Abraçadeira Suporte para tubos (vide ilustração de Abraçadeira Suporte p/tubo)

**Abraçadeira Suporte para Tubo Haste Fixa**

Ø	A	B	C
1/2"	12,7	59,0	3/4"
3/4"	19,5	65,0	3/4"
1"	25,5	80,0	3/4"
1 1/2"	35,5	94,0	3/4"
2"	51,5	113,0	3/4"
2 1/2"	64,0	127,0	3/4"
3"	76,5	144,0	3/4"
4"	102,0	168,0	3/4"

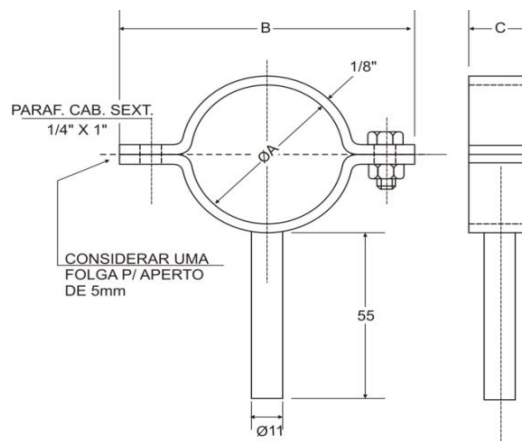

**Morsa e Boco de Expansão**

Bitola
1"
1½"
2"
2½"
3"

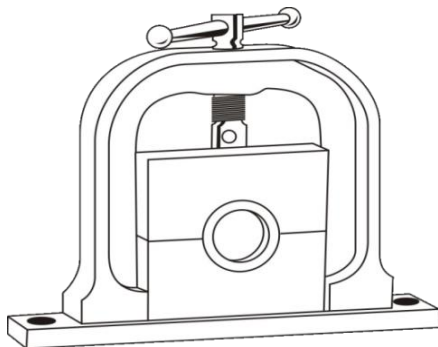

**Expandidor**

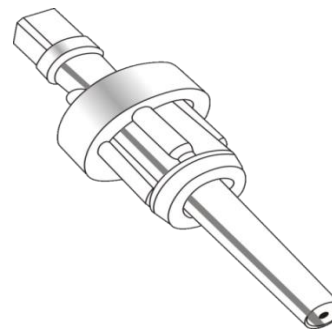

Bitola	torque p/exp Kgf.m
1"	2,0
1½"	4,0
2"	8,0
2½"	14,0
3"	17,0

**Chave para Porca**

Bitola
1"
1½"
2"
2½"
3"
4"
5"
6"

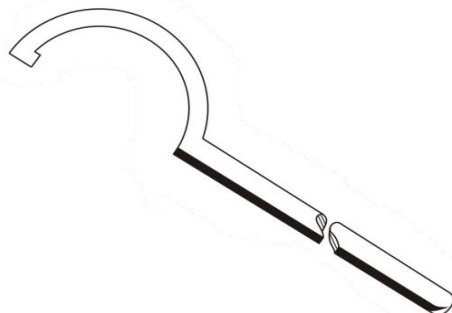

**Guia para Corte de Tubo**

Bitola
1"
1½"
2"
2½"
3"
4"

